



a· amdocs

**make it
amazing**

Network Automation Investor Webinar

The Journey to Streamline & Automate Network
Ecosystems in the 5G & Cloud Era

June 22, 2023

Disclaimer

The information contained herein in this presentation or delivered or to be delivered to you during this presentation does not constitute an offer, expressed or implied, or a recommendation to do any transaction in Amdocs Limited securities or in any securities of its affiliates or subsidiaries.

This presentation and the comments made by members of Amdocs management in conjunction with it include information that constitutes forward-looking statements made pursuant to the safe harbor provision of the Private Securities Litigation Reform Act of 1995, including statements about Amdocs' growth and business results in future quarters. Although we believe the expectations reflected in such forward-looking statements are based upon reasonable assumptions, we can give no assurance that our expectations will be obtained or that any deviations will not be material. Such statements involve risks and uncertainties that may cause future results to differ from those anticipated. These risks include, but are not limited to, the effects of general macro-economic conditions, prevailing level of macroeconomic, business and operational uncertainty, including as a result of geopolitical events or other global or regional events such as the COVID-19 pandemic, as well as the current inflationary environment, and the effects of these conditions on the company's clients' businesses and levels of business activity, Amdocs' ability to grow in the business markets that it serves, Amdocs' ability to successfully integrate acquired businesses, adverse effects of market competition, rapid technological shifts that may render the Company's products and services obsolete, potential loss of a major customer, our ability to develop long-term relationships with our customers, and risks associated with operating businesses in the international market. Amdocs may elect to update these forward-looking statements at some point in the future; however, Amdocs specifically disclaims any obligation to do so. These and other risks are discussed at greater length in Amdocs' filings with the Securities and Exchange Commission, including in our Annual Report on Form 20-F for the fiscal year ended September 30, 2022 filed on December 13, 2022 and our Form 6-K furnished for the first quarter of fiscal 2023 on February 13, 2023, and for the second quarter of fiscal 2023 on May 22, 2023.

This presentation includes non-GAAP financial measures, including non-GAAP operating margin, free cash flow, revenue on a constant currency basis, non-GAAP net income, non-GAAP net income attributable to Amdocs Limited, and non-GAAP earnings per share. Free cash flow equals cash generated by operating activities less net capital expenditures and other. While in prior years Amdocs used normalized free cash flow, a measure of our operating performance, is further adjusted to exclude net capital expenditures related to the new campus development, payments for non-recurring and unusual charges (such as capital gains tax to be paid in relation to the divestiture of OpenMarket), and payments of acquisition related liabilities, Amdocs is no longer reporting normalized free cash flow. Normalized free cash flow is not comparable to free cash flow. These non-GAAP financial measures are not in accordance with, or an alternative for, generally accepted accounting principles and may be different from non-GAAP financial measures used by other companies. In addition, these non-GAAP financial measures are not based on any comprehensive set of accounting rules or principles. Amdocs believes that non-GAAP financial measures have limitations in that they do not reflect all of the amounts associated with Amdocs' results of operations as determined in accordance with GAAP and that these measures should only be used to evaluate Amdocs' results of operations in conjunction with the corresponding GAAP measures. Please refer to the appendix for a reconciliation of these metrics to the most comparable GAAP provision.

This presentation also includes pro forma metrics which exclude the financial impact of OpenMarket (divested on December 31, 2020) from fiscal year 2021.

Please also review the information contained in Amdocs' press release dated May 10, 2023 with respect to earnings for fiscal Q2 2023. The press release contains additional information regarding Amdocs' outlook for fiscal year 2023 and certain non-GAAP metrics and their reconciliations.

Today's Speakers



Matthew Smith

Amdocs Head of Investor Relations



Niall Norton

Amdocs Networks Division President, General Manager



Ana Redondo

Amdocs Networks, Product Strategy Lead



Gint Atkinson

Vice President Network Strategy & Architecture, SES, an Amdocs customer



Agenda

1

Welcome & Introduction

Matt Smith, Amdocs Head of Investor Relations

2

Amdocs' End to End Network Automation Journey

Niall Norton, Amdocs Networks Division President, General Manager

3

Meeting the Network Automation Need

Ana Redondo, Amdocs Networks Product Strategy Lead

4

Network Automation – Customer Perspective

Gint Atkinson, Vice President Network Strategy & Architecture, SES

5

Q&A



Amdocs is a leading provider of mission critical software and services to communications and media companies, powering the delivery of customer experiences on a global scale...

We...

- ▶ digitalize and automate operations
- ▶ accelerate migration to the cloud
- ▶ create differentiation in the 5G era
- ▶ ensure ubiquitous connectivity
- ▶ enable monetization

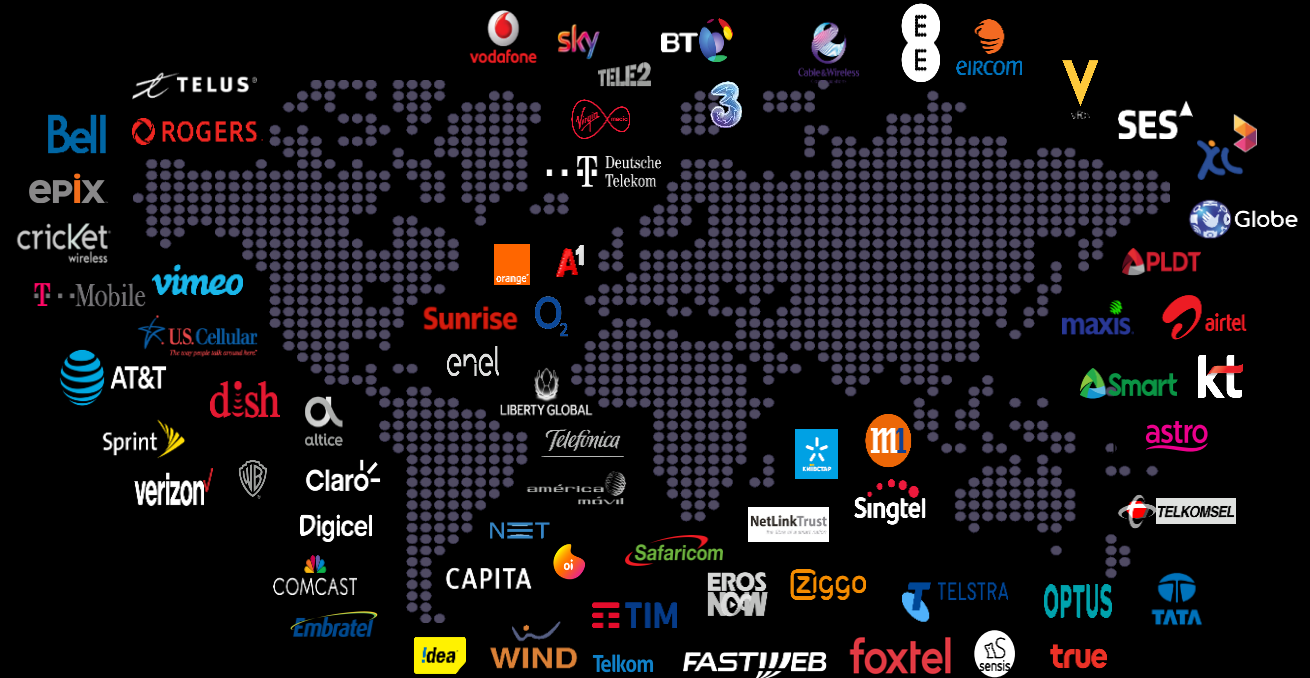

31,000
Employees



\$4.58B
FY22 Revenues,
+10.3% YoY1



350+ customers
Industry in society's
backbone



\$1B+ investment
In our next-gen cloud platform



~75%
Recurring revenue



90
Countries



Best technologies
Driving a leadership
position



Committed to sustainability
Dow Jones Sustainability Index
Top workplace for women in India
for 2021

Our strategic framework supports the industry's ever-changing business needs with innovative technology



DIGITAL

Creating **seamless** digital experiences by **transforming** IT operations



5G

Enable 5G **monetization**: new 5G services and support of exciting **new** 5G use cases



CLOUD

Journey to the cloud: Accelerate cloud adoption across **all platforms** and customer base



**NETWORK
AUTOMATION**

Delivering dynamic connected experiences with **real-time, automated** networks



Our strategy translates to a serviceable addressable market estimated at **~\$57 billion** by 2025

Amdocs' End to End Network Automation Journey

Niall Norton

Amdocs Networks Division President,
General Manager



Advancing Amdocs' Network Capabilities for More Than 15 Years

Leveraging innovative R&D, strategic M&A and industry-leading partners

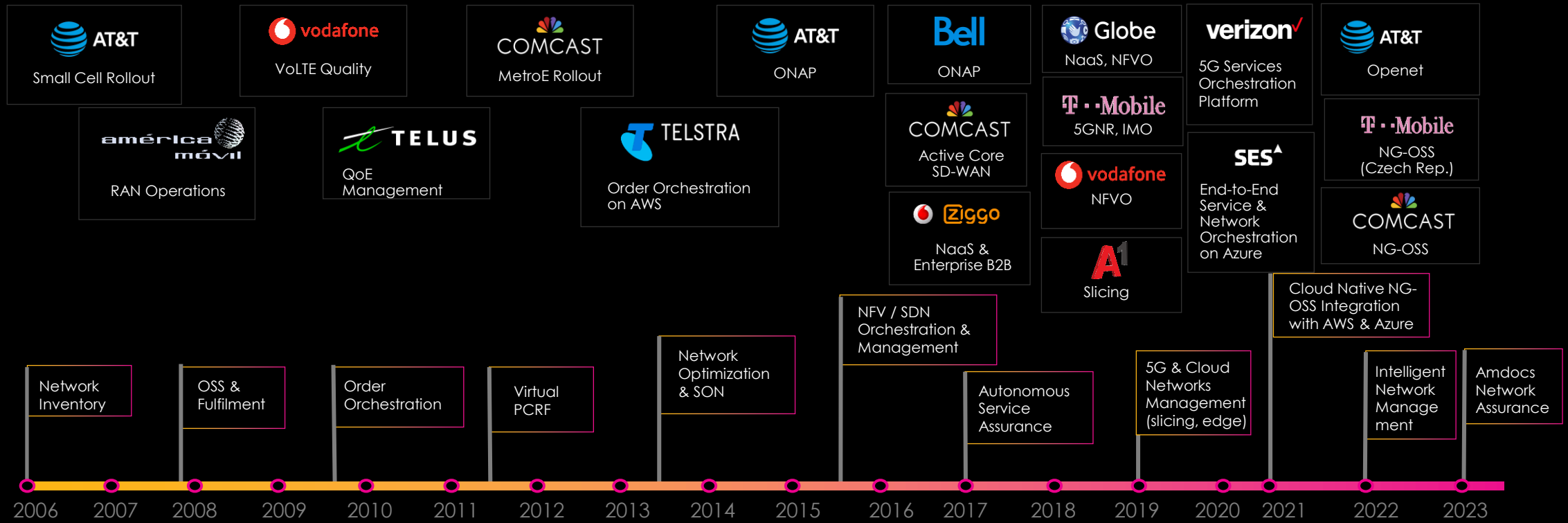

100+
partners worldwide

(1) Signed agreement to acquire service assurance business of TEOCO for \$90 million; acquisition expected to close by end of fiscal year 2023



We are entering a ubiquitous connectivity era, shaped by multiple forces



New Opportunities

Software-defined, programmable networks bring opportunities to offer new, differentiated services

Enterprise,
industrial
Network



Evolved
Consumer
Network



Transformation Shift in Business Model of Telcos

Connectivity & other traditional services will gradually be joined by new revenue opportunities

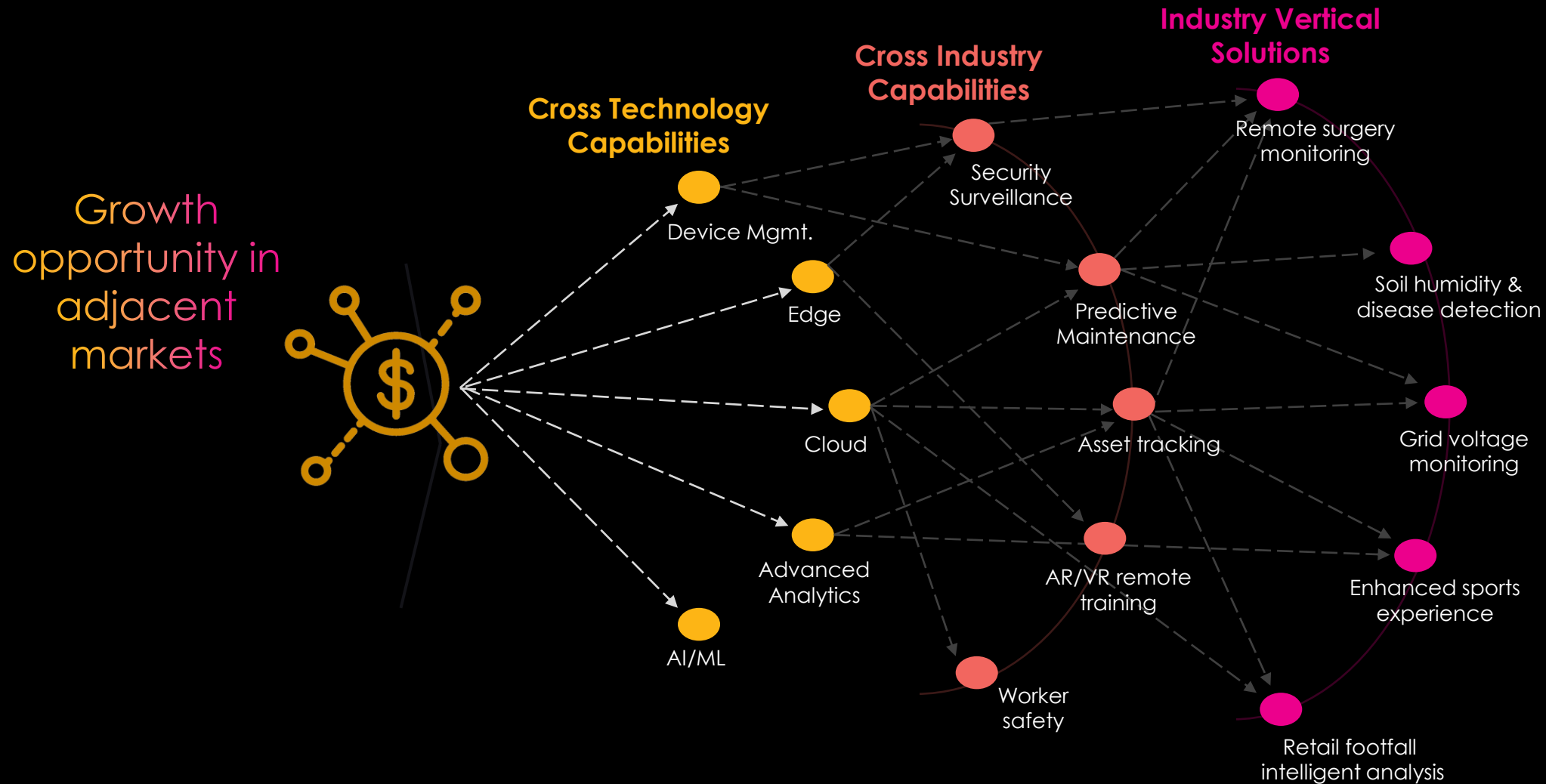

Technology is Moving Faster Than Ever

CSPs must operate in a complex ecosystem that includes rapidly changing **market dynamics**, **exponential technology shifts**, and quickly evolving **human adoption** behaviors

We have reached an inflection point, and CSPs must react quickly to changes and prepare for an uncertain future

Exhibit 2: The accelerating pace of change

Year Developed	Technology	Years until mass adoption
1872	Electricity	46
1876	Telephone	35
1897	Radio	31
1926	Television	26
1975	PC	16
1983	Mobile Phone	13
1991	The Web	7
2001	iPod	4
2006	Facebook	3
2007	iPhone	2.5

Source: Augmented

ChatGPT Sprints to One Million Users

Time it took for selected online services to reach one million users



* one million backers ** one million nights booked *** one million downloads
Source: Company announcements via Business Insider/LinkedIn



statista

Intelligent Automation is the only way to address these changes:

- ✓ Fast launch timelines
- ✓ Explosion of device/service launches
- ✓ Cost effectiveness

Monetizing Advanced Networks is a Multi-Year Journey

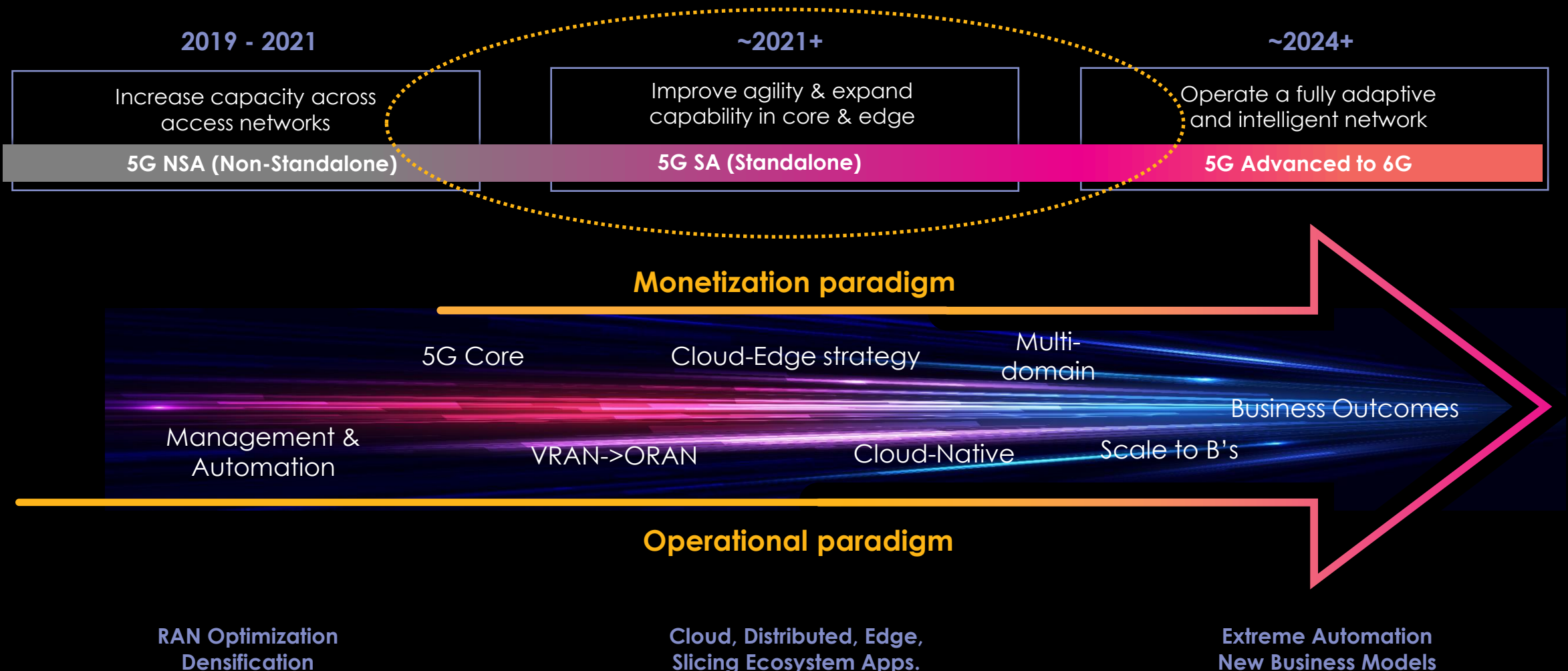

Automation is Inevitable in Growing Industries

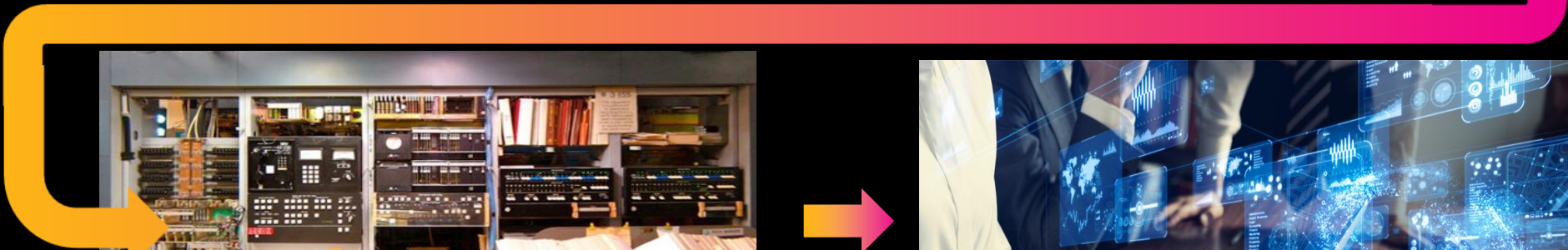
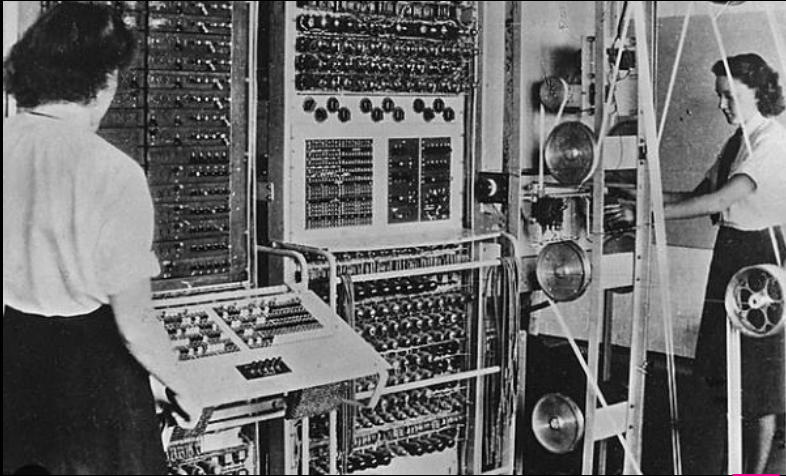
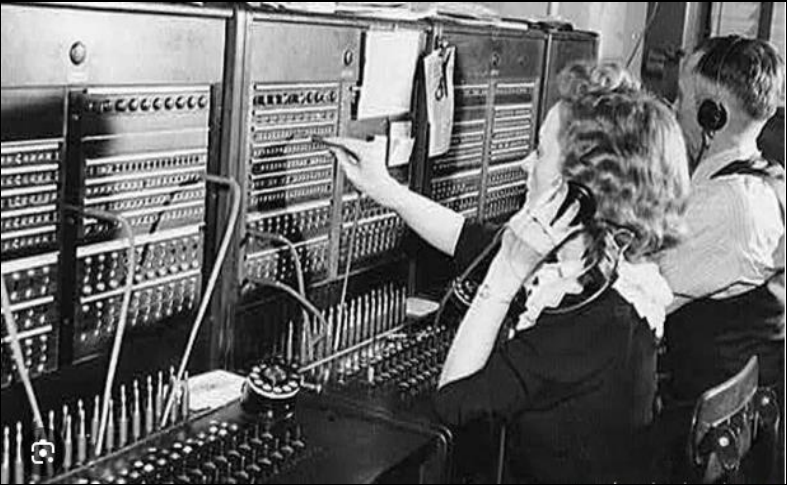

Intelligent Automation is the Path to Deliver Business Value

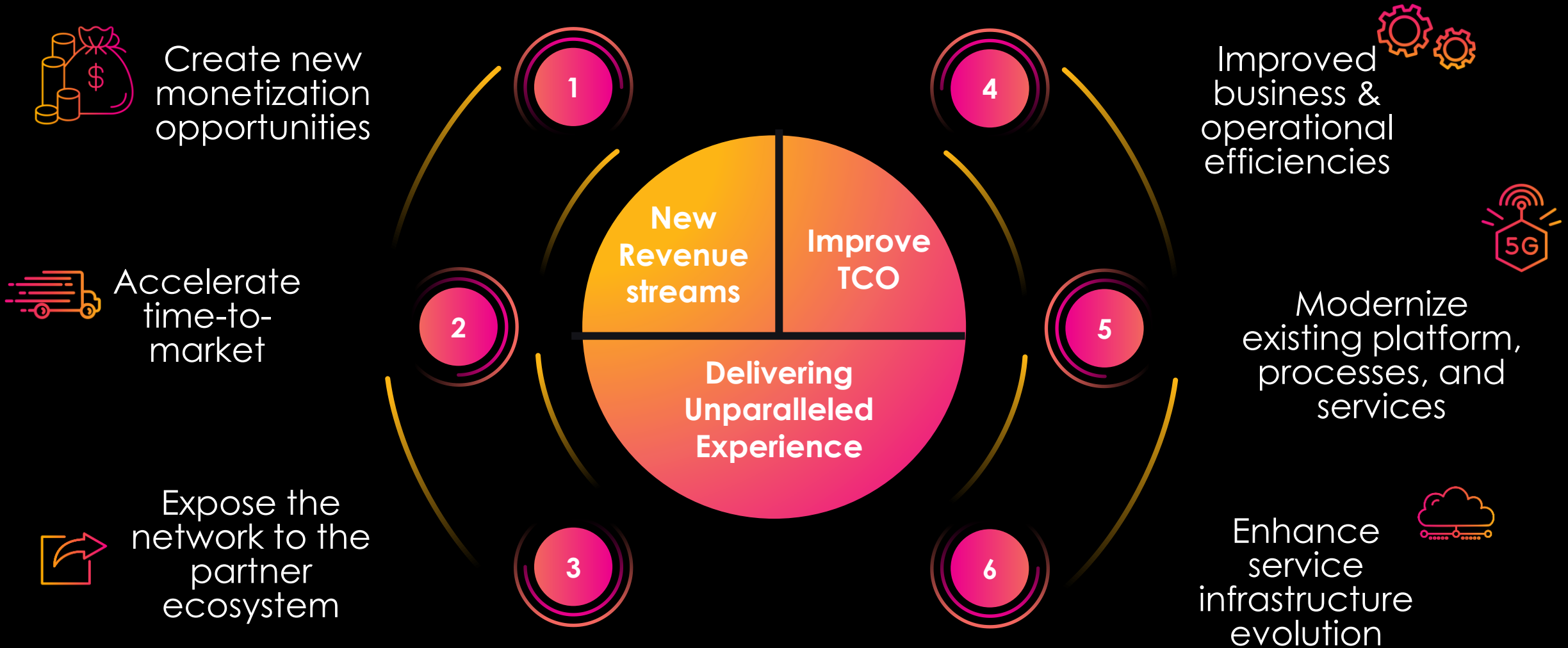

Intelligent Automation is an Industry Imperative

The market acknowledges the need



CSPs will place a **greater emphasis on efficiency and will continue with automation efforts** that they initiated during the pandemic.



CSPs are focusing on **automation of their network operations** to improve **efficiency and customer experience** and mitigate security concerns.



As CSPs move into a more dynamic, distributed and programmable network era, **automation platforms will be required** to support operations and management for the networks of today and tomorrow.

There's still a substantial job to be done



Telco Network Automation Survey – 2022

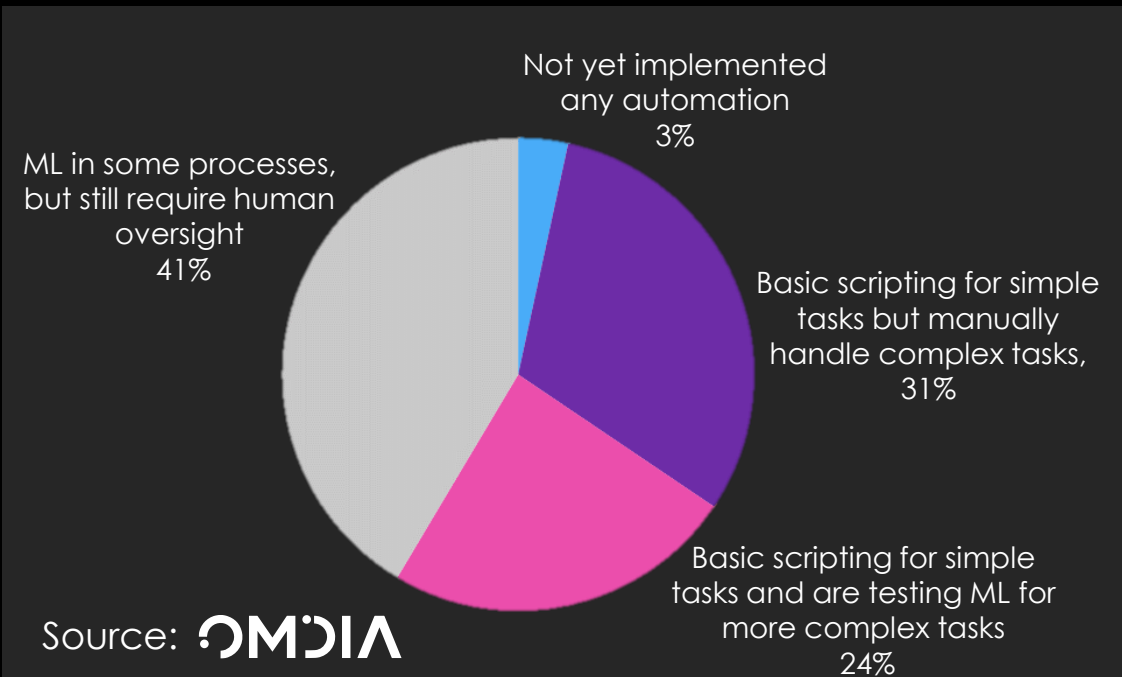

Source: OMDIA

State of Telco Network Automation adoption

What has Delayed Automation, and Why is it an Opportunity for Us?

We help tackle the industry's biggest challenges:

- The environment is complex – CSPs still need to support multiple forms of connectivity
- New technology and tools – moving from physical to virtual/cloud/edge
- People - new business processes, new business culture requirements
- Transformation programs – CSPs require help to successfully execute



Amdocs Networks: What We Believe...

Leaders don't respond to disruption. They disrupt, modify and improve themselves; changing the game before it changes them

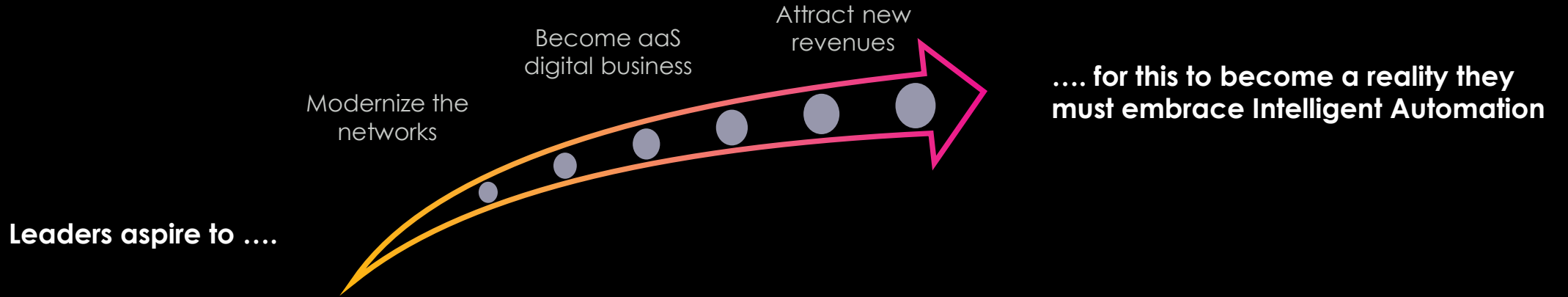

Amdocs is innovating to enable Intelligent Network Automation

Vendor Independent



Software-led



Multi-domain Expertise



Proven at Tier-1 Operators



Meeting the Network Automation Need

Ana Redondo

Amdocs Network Strategy Product Lead



What is Network Automation?

It is software that links the business systems and the network infrastructure, and is used to automate the infrastructure deployed and services sold to customers

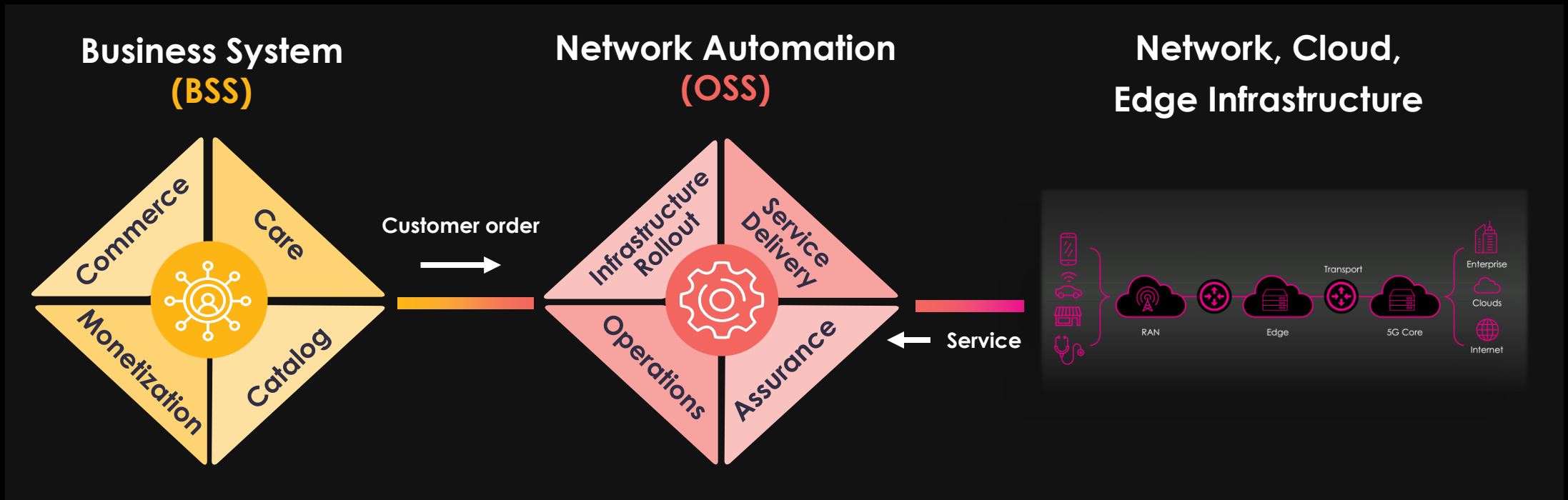

Key link between BSS and Infrastructure

- ✓ Deliver reliably
- ✓ Deliver on-time
- ✓ Deliver cost effectively

Is Automation Really Needed?

The scale and complexity Telcos must deal with, cannot be handled manually

Simple Network Schematic View

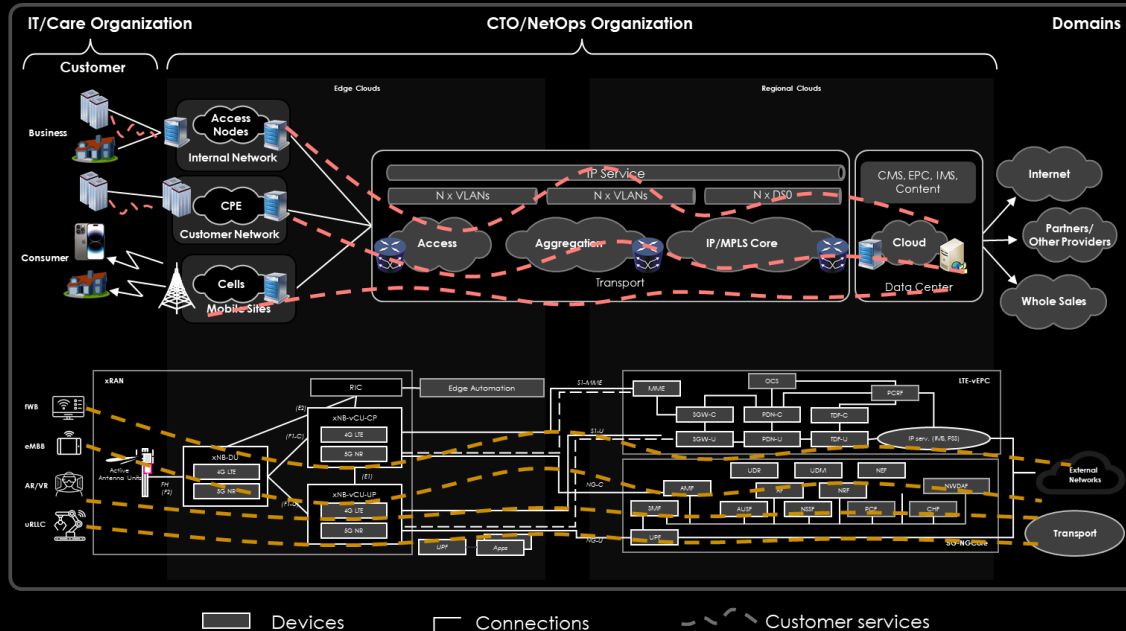

Mid-sized Telco network can have

- 100K+ devices (HW & SW)
- 10m+ connections
- 50m+ customer services

Across ...

- 25+ data centres / cloud storage
- 30+ vendors
- 10+ new and legacy networks

Telcos must deploy all this infrastructure and services and maintain it all

Would you do this and by hand?

The World Where Automation Operates is Changing

Networks are gradually becoming software driven and delivering services to increasingly demanding customers

New software driven networks

Virtualized Cloud native Dynamic sizing
Multi vendor Multi technology

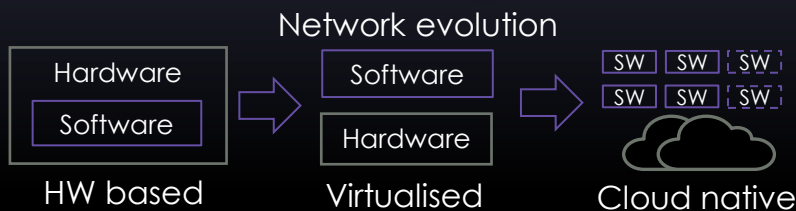

New customer demands

Dynamic services Customer driven Price smart
Services in minutes Always 'on'



New agile, intelligent automation is needed

How Automation has Evolved to Meet New Demands

Traditional way ... "How"

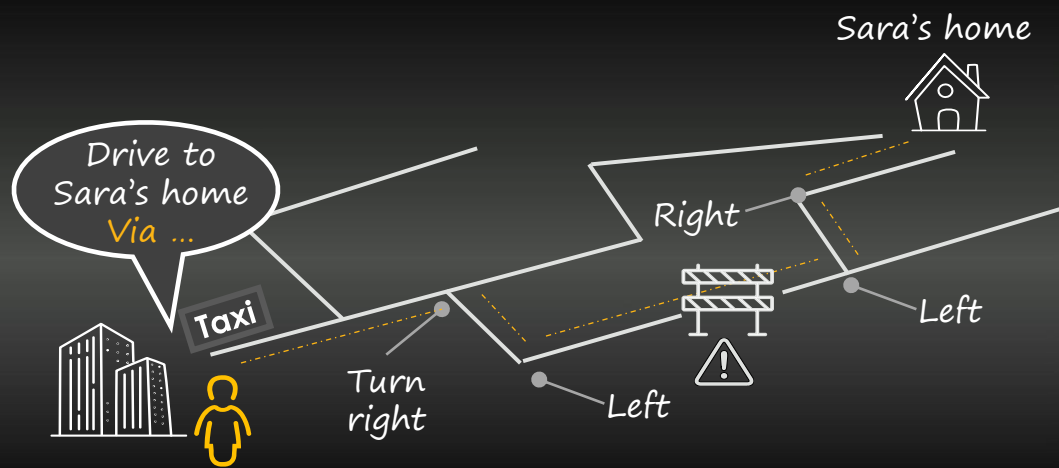

New way ... "What"

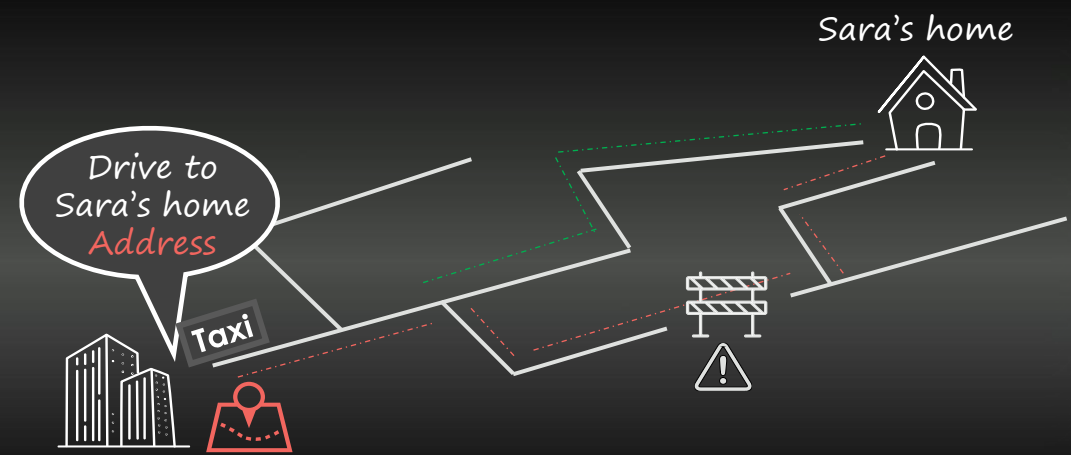

Procedural driven 

Expert driven 

Manually fixed 

 Intent driven

 Intelligence driven

 Predictive, observable, closed loop fixed

Customer and service centric
Dynamic, agile and intelligent Automation

A New Era of Intelligent Automation

Intent-driven, AI/ML driven, closed-loop operations

Business System (BSS)
Consumer service example



Deliver premium gaming service for customer in address ...

Identify impact and cause, e.g. server overutilized

Observe network feedback, events, telemetry e.g. latency 20ms

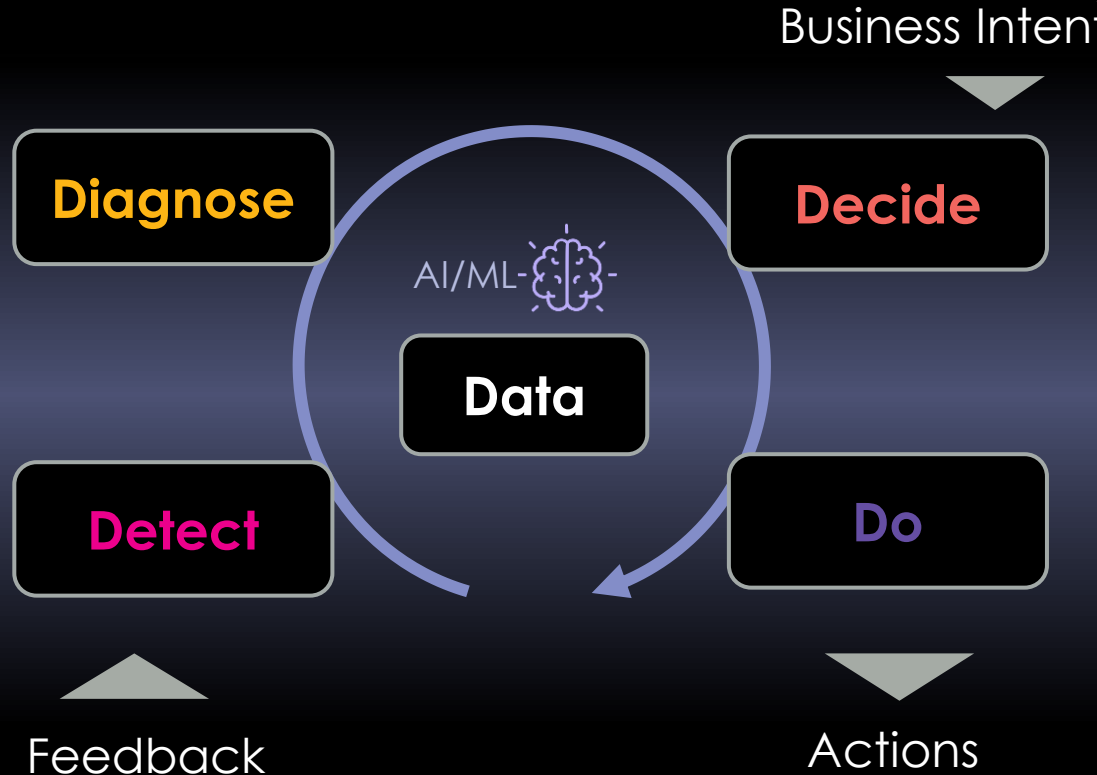

Decide based on the business intent, e.g., latency < 10ms

Do the actions to meet business intent, e.g., select edge cloud

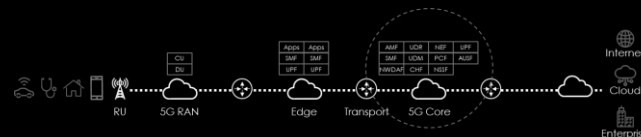

Amdocs Solution for Intelligent Automation



Amdocs Intelligent Networking Suite

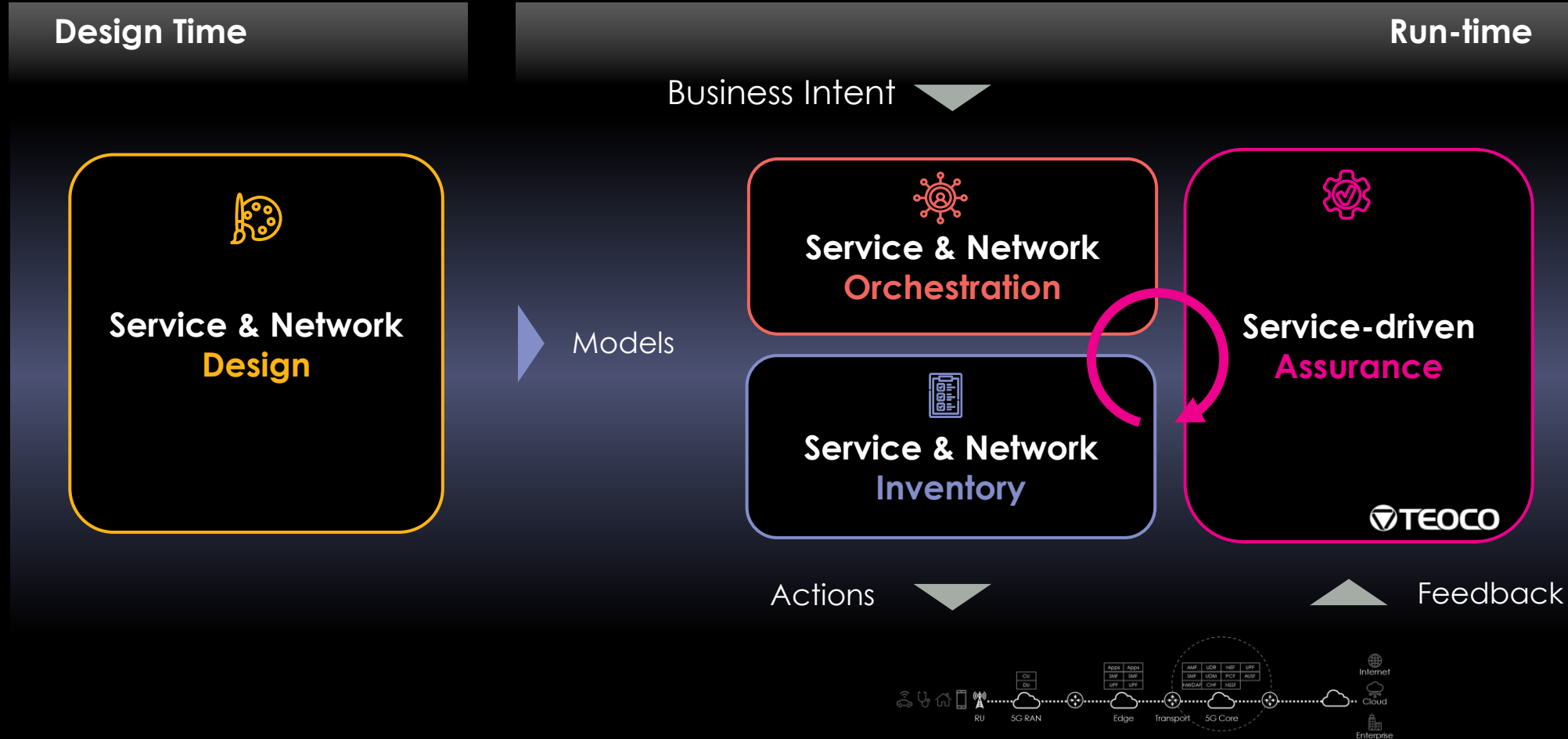



Improving agriculture industry processes with automation

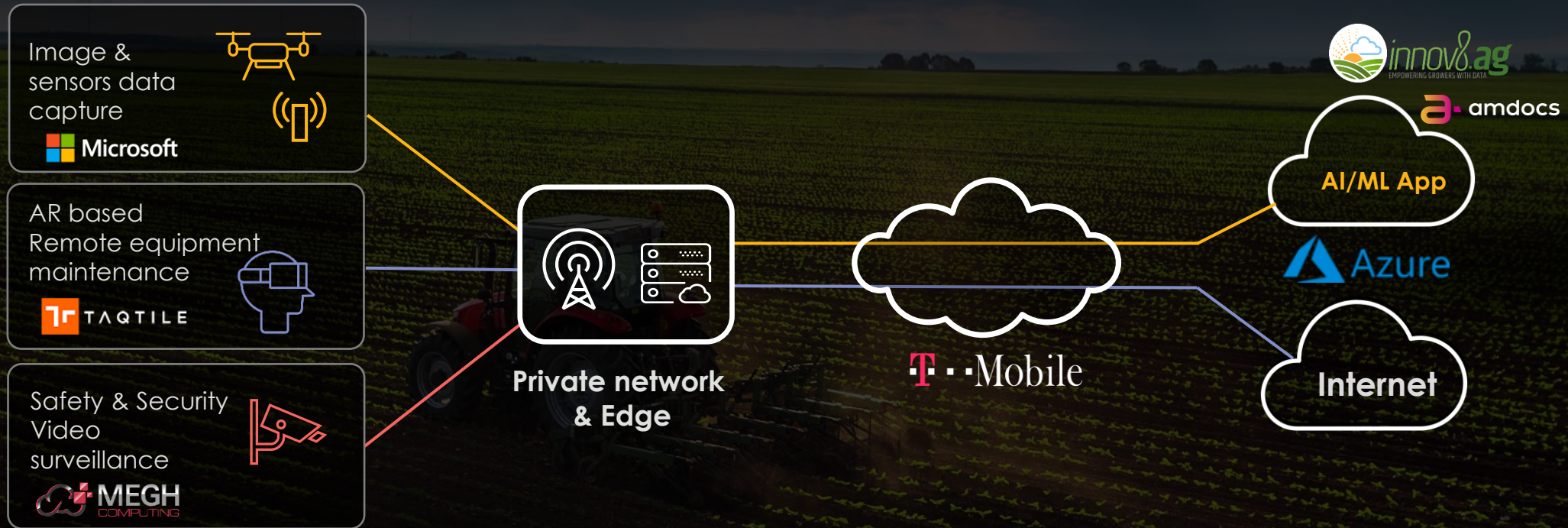

← Fully automated by Amdocs Intelligent Networking Suite →

✓ Infrastructure rollout

✓ Application deployment

✓ End-to-end service connection

✓ Solution operations

An aerial photograph of an apple orchard at dawn. The rows of trees stretch far into the distance, creating a strong sense of perspective. The lighting is soft and golden, typical of early morning. In the background, a red barn with a white roof and a communication tower on top is visible. The sky is a pale, hazy blue, and distant hills can be seen on the horizon.

Time: 07:01 a.m.

A drone is sent to scan an apple orchard using high-fidelity 4K images

Time: 07:02 a.m.

Tens of gigabits of 4K resolution drone images were transferred over a 5G private-enterprise network to an edge server for analysis



Time: 07:03 a.m.

The edge server stitches and compresses the images and sends them over T-Mobile's Public Network to Microsoft Azure Cloud, for analysis



Time: 07:04 a.m.

Images are processed in near-real time on the Microsoft Azure Cloud, using advanced algorithms and machine learning



Time: 07:05 a.m.

The farmer receives a robust set of real-time, actionable insights on the orchard – like irrigation, fertilization, pesticide, crop density and more

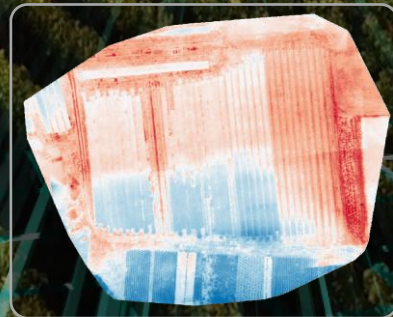
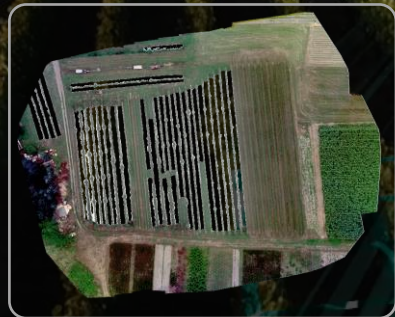

A photograph of a farmer wearing a straw hat and a plaid shirt, holding a red apple in one hand and a tablet in the other, standing in an orchard. The background shows rows of apple trees and a crate filled with apples.

Results:

Increase in crop yields,
50% reduction in water usage
and better visibility as to where
water should be applied

A process that used to take days
is now possible in a few minutes

Customer Perspective

A discussion with Gint Atkinson, Vice President
Network Strategy & Architecture, SES



Q&A



A person stands with their back to the camera on a highly reflective surface, looking out at a futuristic city skyline at night. The city is illuminated with vibrant blue and purple lights, and the lights are reflected on the surface below. The sky is dark with some clouds.

amazing doesn't just **happen**

Thank you

Behind the experiences that make the world say wow, you'll find us:
helping those who shape the future,
to **make it amazing**